

DATA SHEET

DIRECT DRIVE PLUNGER PUMPS



**Stainless Steel
Models:**

**2SF05SEEL, 2SF10SEEL, 2SF15SEEL,
2SF22SEEL**

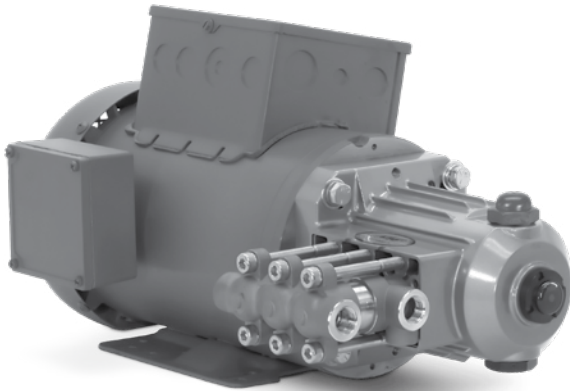

Motorized pump unit 2SF22SEELD Shown

SPECIFICATIONS	U.S. Measure	Metric Measure
Model 2SF05SEEL		
Flow	0.5 gpm	1.9 lpm
Stroke	0.071"	1.8 mm
Model 2SF10SEEL		
Flow	1.0 gpm	3.8 lpm
Stroke	0.122"	3.1 mm
Model 2SF15SEEL		
Flow	1.5 gpm	5.7 lpm
Stroke	0.177"	4.5 mm
Model 2SF22SEEL		
Flow	2.2 gpm	8.3 lpm
Stroke	0.248"	6.3 mm

FEATURES

- Unique spring loaded inlet valves and the flow through ceramic plungers provides a smooth, steady flow.
- Hollow shaft direct drive to provide the smallest possible footprint for challenging spaces.
- Standard NBR seals with alternative options for temperature and chemical compatibility.

COMMON SPECIFICATIONS

	U.S.	Metric
Pressure Range	100 - 1200 psi	6.9 - 83 bar
Pump RPM	1725 rpm	1725 rpm
Inlet Pressure Range	Flooded to 60 psi	Flooded to 4.1 bar
Max. Liquid Temp. (NBR)	160° F	71° C
Alternative seals available for high temp up to 200° F		
Bore	0.709"	18 mm
Crankcase Capacity	10.1 oz.	0.30 l
Inlet Port (1)	3/8" NPT(F)	3/8" NPT(F)
Discharge Ports (2)	3/8" NPT(F)	3/8" NPT(F)
By-Pass Return Port (1)	1/4" NPT(F)	1/4" NPT(F)
Shaft Diameter	5/8"	15.9 mm
Weight (Pump Only)	8.9 lbs.	4 kg
Dimensions (Pump Only)	6.8 x 8.7 x 5.2"	173 x 221 x 133 mm

ALTERNATIVE SEAL CONFIGURATION

MATERIAL	SUFFIX CODE	MAXIMUM TEMPERATURE	
NBR	—	160° F	(71° C)
FPM	.0110	180° F	(82° C)
EPDM	.0220	160° F	(71° C)
IPFE	.0770	200° F	(93° C)
HT	.3000	180° F	(82° C)
STHT	.3400	200° F	(93° C)

See Reference Document 99REF017 for inlet conditions and RPM at high temperature.

$$\frac{\text{Rated gpm}}{\text{Rated rpm}} = \frac{\text{"Desired" gpm}}{\text{"Desired" rpm}}$$

$$\frac{\text{Hp (Electric Brake)}}{\text{gpm x psi}} = \frac{1460}{\text{gpm x psi}}$$

Refer to pump **Service Manual** for repair procedure and additional technical information.

PARTS LIST

ITEM	PART NUMBER	MATL	DESCRIPTION	MODEL	QTY
5	547445	S	Screw, HHC Sems (M6x14) [3/03]	All	3
8	547153	AL	Cover, Bearing [3/03]	All	1
10	14041	NBR	O-Ring, Bearing Cover-70D [3/03]	All	1
11	55337	NBR	Seal, Oil, Crankshaft -70D [3/03]	All	1
15	14488	STL	Bearing, Ball - Inner	All	1
20	547046	TNM	Rod, Connecting	All	3
25	831987	CM	Crankshaft, 1.8mm	05SEEL	1
	46109	CM	Crankshaft, 3.1mm	10SEEL	1
	44931	CM	Crankshaft, 4.5mm	15SEEL	1
	45160	CM	Crankshaft, 6.3mm	22SEEL	1
26	12385	STL	Ring, Retaining, Bearing	All	1
27	15710	STL	Bearing, Ball - Outer	All	1
31	549726	—	Cap, Vented w/O-Ring (Rain Cap)	All	1
32	547961	RTP	Cap, Oil Filler w/O-Ring	All	1
33	14179	NBR	O-Ring, Oil Filler Cap - 70D	All	1
37	92241	—	Gauge, Oil w/Gasket - 80D	All	1
38	44428	NBR	Gasket, Flat, Oil Gauge - 80D	All	1
48	44842	NY	Plug, Drain	All	1
49	14179	NBR	O-Ring, Drain Plug - 70D	All	1
53	547285	AL	Crankcase (See Tech Bulletin 92)	All	1
64	16948	CM	Pin, Crosshead	All	3
65	834203	SSTO	Rod, Plunger	All	3
69	126259	STCP R	Washer, Oil Seal	All	3
70	25461	NBR	Seal, Oil Crankcase	All	3
90	544697	CC	Plunger, Ceramic (M18x18)	All	3
100	44869	PVDF	Retainer, Seal	All	3
106	547683	NBR	Seal, LPS w/SS-Spg	All	3
	◆ 545192	FPM	Seal, LPS w/SS-Spg	All	3
	546507	EPDM	Seal, LPS w/SS-Spg	All	3
	76443	ST	Seal, LPS	All	3
110	547704	SS	Manifold, Inlet	All	1
125	44652	SNG	Seal, HPS w/SS	All	3
	46652	HT	Seal, Hi-Temp, 2-Pc w/S-Support	All	3
	76052	ST4	Seal, HPS w/s	All	3
134	543691	SS	Valve, Inlet (See Tech Bulletin 91)	All	3
	33873	D	Valve, Inlet (See Tech Bulletin 91)	All	3
135	543689	SS	Spacer	All	3
136	543690	SS	Spring, Inlet Valve	All	3
137	88575	S	Washer, Conical (M6)	All	3
138	543692	SS	Nut (M6)	All	3
152	† 26089	NBR	O-Ring, Adapter Spacer, Inner-80D	All	3
	11377	FPM	O-Ring, Adapter Spacer, Inner-80D	All	3
	◆ 46647	EPDM	O-Ring, Adapter Spacer, Inner-80D	All	3
157	544700	SS	Adapter, Valve	All	3
159	† 26089	NBR	O-Ring, Adapter Spacer, Outer-80D	All	3
	11377	FPM	O-Ring, Adapter Spacer, Outer-80D	All	3
	◆ 46647	EPDM	O-Ring, Adapter Spacer, Outer-80D	All	3
164	544293	SS	Seat	All	3
166	543669	SS	Valve	All	3
167	543700	SS	Spring	All	3
168	44565	PVDF	Retainer, Spring	All	3
185	547705	SS	Manifold, Discharge	All	1
188	544701	S	Screw, HSH (M8x80)	All	6
255	30517	STZP R	Assy, Bolt Mount	All	1
300	34973	NBR	Kit, Seal (Incls: 106, 125, 152, 159) Standard	All	1
	33453	FPM	Kit, Seal (Incls: 106, 125, 152, 159) .0110	All	1
	◆ 30536	EPDM*	Kit, Seal (Incls: 106, 125, 152, 159) .0220	All	1
	33953	HT	Kit, Seal Hi-Temp (Incls: 106, 125, 134, 152, 159) .3000	All	1
310	34972	NBR	Kit, Valve (Incls: 152,159,164,166,167,168) Standard	All	1
	33454	FPM	Kit, Valve (Incls: 152,159,164,166,167,168) .0110	All	1
	◆ 30546	EPDM	Kit, Valve (Incls: 152,159,164,166,167,168) .0220	All	1
311	39668	NBR	Kit, Inlet Valve w/SS-IV (Incls:134-138,152,159) Standard	All	1
	34974	NBR	Kit, Inlet Valve w/D-IV (Incls:134-138,152,159)	All	1
	33460	FPM	Kit, Inlet Valve w/D-IV (Incls:134-138,152,159) .0110	All	1
	◆ 30556	EPDM	Kit, Inlet Valve w/D-IV (Incls:134-138,152,159) .0220	All	1
—	6107	—	Oil, Bottle (21 oz) ISO-68 Hydraulic (Fill to specified crankcase capacity prior to start-up)	All	1

Bold print part numbers are unique to a particular pump model. *Italics are optional items.* ◆ Silicone oil/grease required.

[] Date of latest production change. † Production parts are different than repair parts. R Components comply with RoHS Directive.

*Review individual parts in each kit for material code identification. View Tech Bulletins 002, 036, 043, 055, 064, 070, 073, 074, 083, 091, 092 and 124 for additional information.

NOTE: Discard Key that may come standard with most motors and engines and use only the key included in Bolt kit.

MATERIAL CODES (Not Part of Part Number): AL=Aluminum CC=Ceramic CM=Chrome-Moly D=Acetal EPDM=Ethylene Propylene Diene Monomer FPM=Fluorocarbon
HT=Hi-Temp (EPDM Alternative) NBR=Medium Nitrile (Buna-N) NY=Nylon PVDF=Polyvinylidene Fluoride RTP=Reinforced Composite S=304SS SNG=Special Blend (Buna) SS=316SS
SSTO=316SS/Titanium Oxide ST=Special PTFE ST4=Special PTFE 4 STL=Steel STCP=Steel/Chrome Plated STZP=Steel/Zinc Plated TNM=Special High Strength

EXPLODED VIEW

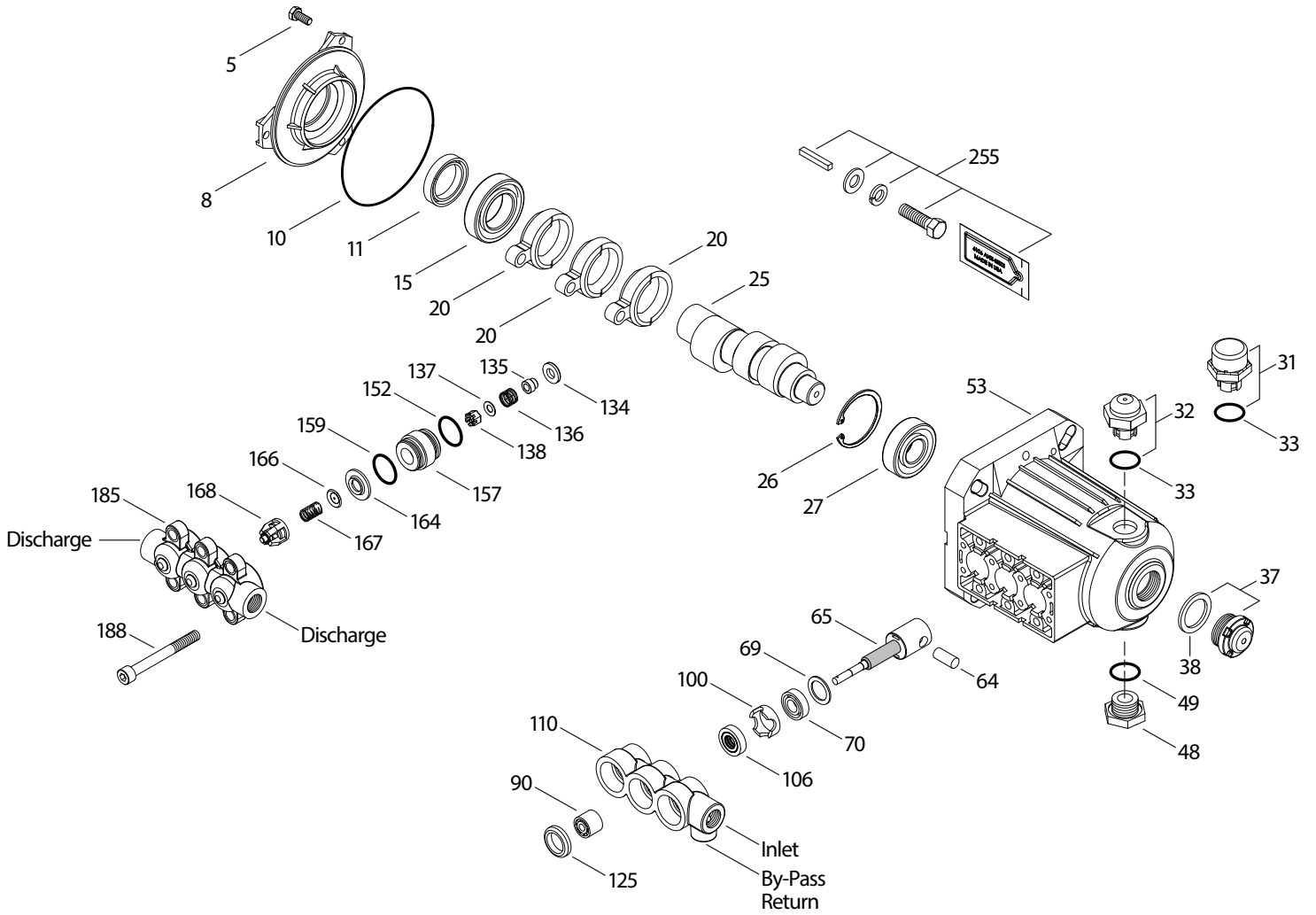

MODEL	8105	8175	8110	8060	8062	8125/8125W
Dimension A	15.9	15.9	17.1	18.7	19.2	19.0
Dimension B	9.0	9.0	10.2	11.8	12.3	12.2
Dimension C	8.2	8.2	8.2	8.1	8.1	9.6
Dimension D	9.1	9.1	9.1	9.5	9.5	9.7

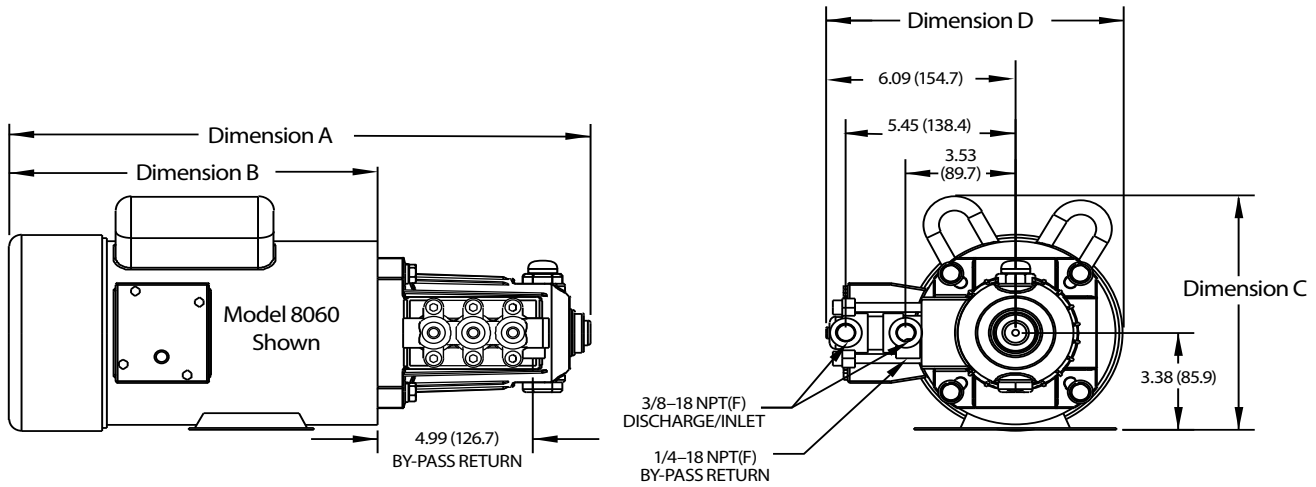

Models 2SF05SEEL, 2SF10SEEL, 2SF15SEEL, 2SF22SEEL

MOTOR SPECIFICATIONS

MODEL	8105	8175	8110	8060	8062	8125/8125W
HorsePower	0.5	0.75	1.0	1.5	2.0	2.5/2.2
Phase	Single	Single	Single	Single	Single	Single
RPM	1750	1745	1750	1725	1725	1750/1450
Frame Size	56C TEFC	56C TEFC	56C TEFC	56C TEFC	56C TEFC	56HC TEFC
Shaft Diameter (inches)	5/8	5/8	5/8	5/8	5/8	5/8
Maximum Volts	115/208-230	115/208-230	115/208-230	115/230	115/230	115/230, 110/220
Full Load Amps	7.4/3.6-3.7	10.6/5.2-5.3	14/6.8-7.0	14.0/7.0	17.0/8.5	20.8/10.4, 22/11
Hertz	60	60	60	60	60	60/50
Service Factor	1.15	1.15	1.15	1.2	1.15	1.15
Max. Ambient Temp. (°F)	104	104	104	104	104	104
Capacitor Start	Yes	Yes	Yes	Yes	Yes	Yes
Thermal Overload-Manual Reset	No	Yes	No	Yes	Yes	No
Weight (lbs.)	25	28	34	42	45.7	52.9

NOTE: Motor start-up Amps may vary, then settle within Full Load Amps rating after initial run time.

Before mounting pump on motor, apply P.N. 6106 Antiseize Lubricant to pump shaft.

Refer to Tech Bulletin 055 for instructions on removing pump from electric motor.

For electric motor warranty consideration contact motor manufacturer's local Authorized Service Center.

CAUTIONS AND WARNINGS

All High Pressure Systems require a primary pressure regulating device (i.e. regulator, unloader) and a secondary pressure relief device (i.e. pop-off valve, relief valve). Failure to install such relief devices could result in personal injury or damage to pump or property. Cat Pumps does not assume any liability or responsibility for the operation of a customer's high pressure system.

Read all CAUTIONS and WARNINGS before commencing service or operation of any high pressure system. The CAUTIONS and WARNINGS are included in each service manual and with each Accessory Data sheet. CAUTIONS and WARNINGS can also be viewed online at www.catpumps.com/cautions-warnings or can be requested directly from Cat Pumps.

WARRANTY

View the Limited Warranty on-line at www.catpumps.com/warranty.