

DATA SHEET

SLEEVED DIRECT DRIVE PLUNGER PUMP



The Pumps with Nine Lives

**Brass Electric
Models:**

4SF40ELS, 4SF45ELS, 4SF50ELS

**Brass Gas
Models:**

4SF35GS1, 4SF40GS1, 4SF45GS1, 4SF50GS1

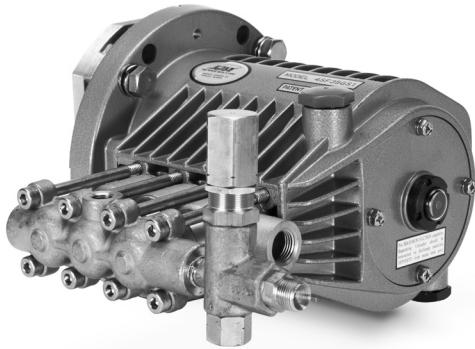

Model 4SF40GS1 Shown
(Unloader included with pump)

FEATURES

- Triplex design provides smoother liquid flow.
- Unique spring loaded inlet valves and the flow through ceramic plungers allow excellent suction capabilities.
- Compact, hollow shafted pump for direct mounting to either gas or electric motor, eliminates the need for pulleys, belts, gearboxes.
- Regulating Unloader mounts directly on each pump to assure system pressure control and pump protection.
- Convenient multiple porting provides installation flexibility.
- Mounting Flange: SAE J609, Flange B, Extension 4 (1"Ø), Shaft Length = 3 1/4" Pilot Ø = 5 3/4", B.C. Ø = 6 1/2", Thread = 3/8"-16 UNC TAP

COMMON SPECIFICATIONS

	U.S.	Metric
Inlet Pressure Range (Electric)	-2 to 75 psi	-0.14 to 5.17 bar
Inlet Pressure Range (Gas)	Flooded to 75 psi	Flooded to 5.17 bar
Std. Operating Temperature*	160° F	71° C
Bore	0.787"	20 mm
Crankcase Capacity	23.66 oz.	0.70 l
Inlet Port (1)	1/2" NPT(F)	1/2" NPT(F)
By-Pass Port (1)	3/8" NPT(F)	3/8" NPT(F)
Discharge Ports (2)	3/8" NPT(F)	3/8" NPT(F)
Auxiliary Port (1)	1/4" NPT(F)	1/4" NPT(F)
Weight (Pump only)	24.31 lbs.	11.0 kg
Dimensions (Pump only)	8.23 x 11.20 x 12.33"	209 x 284 x 313 mm

*Above 130°F call Cat Pumps for inlet conditions and elastomer recommendations.

SPECIFICATIONS

U.S. Measure

Metric Measure

4SF40ELS - Electric Model

Flow	4.0 gpm	15 lpm
Max. Discharge Pressure	3500 psi	241 bar
Max. RPM	1725 rpm	1725 rpm
Stroke	0.382"	9.7 mm

4SF45ELS - Electric Model

Flow	4.5 gpm	17 lpm
Max. Discharge Pressure	3000 psi	207 bar
Max. RPM	1725 rpm	1725 rpm
Stroke	0.437"	11.1 mm

4SF50ELS - Electric Model

Flow	5.0 gpm	19 lpm
Max. Discharge Pressure	3000 psi	207 bar
Max. RPM	1725 rpm	1725 rpm
Stroke	0.453"	11.5 mm

4SF35GS1 - Gas Model

Flow	3.5 gpm	13.2 lpm
Max. Discharge Pressure	3500 psi	241 bar
Max. RPM	3200 rpm	3200 rpm
Stroke	0.197"	5.0 mm

4SF40GS1 - Gas Model

Flow	4.0 gpm	15 lpm
Max. Discharge Pressure	3500 psi	241 bar
Max. RPM	3200 rpm	3200 rpm
Stroke	0.224"	5.7 mm

4SF45GS1 - Gas Model

Flow	4.5 gpm	17 lpm
Max. Discharge Pressure	3000 psi	207 bar
Max. RPM	3200 rpm	3200 rpm
Stroke	0.256"	6.5 mm

4SF50GS1 - Gas Model

Flow	5.0 gpm	19 lpm
Max. Discharge Pressure	3000 psi	207 bar
Max. RPM	3200 rpm	3200 rpm
Stroke	0.276"	7.0 mm

ELS = Electric 1-1/8" hollow shaft with bolt mount

GS1 = Gas 1" hollow shaft with bolt and adapter mount

PARTS LIST

ITEM	PART NUMBER	MATL	DESCRIPTION	MODEL USED	QTY
4	125824	STCP R	Screw, HHC Sems (M6x16)	All Models	4
5	126541	STCP R	Screw, HHC Sems (M6x20)	All Models	4
6	150810	NBR	Washer, Seal (M6)	All Models	4
7	45707	AL	Cover, Bearing (Outer)	All Models	1
8	45172	AL	Case, Bearing (Inner)	All Models	1
9	127026	STCP R	Washer, Bearing	All Models	1
10	89811	NBR	O-Ring, Bearing Cover	All Models	1
11	141852	NBR	Seal, Oil	All Models	1
12	14037	NBR	O-Ring, Bearing Cover	All Models	1
14	45174	STL	Bearing, Ball (Inner)	All Models	1
15	45175	STL	Bearing, Ball (Outer)	All Models	1
20	45572	HS	Rod, Connecting	All Models	3
25	46161	FCM	Crankshaft (5.0mm)	35GS1	1
	45575	FCM	Crankshaft (5.7mm)	40GS1	1
	45574	FCM	Crankshaft (6.5mm)	45GS1	1
	45571	FCM	Crankshaft (9.7mm)	40ELS	1
	45570	FCM	Crankshaft (11.1mm)	45ELS	1
	45741	FCM	Crankshaft (11.5mm)	50ELS	1
	46315	FCM	Crankshaft (7.0mm)	50GS1	1
32	45690	RTP	Cap, Oil Filler	All Models	1
33	14179	NBR	O-Ring, Oil Filler Cap - 70D	All Models	1
37	92241	—	Gauge, Bubble Oil w/Gasket - 80D	All Models	1
38	44428	NBR	Gasket, Flat Flex - 80D	All Models	1
48	44842	NY	Plug, Drain	All Models	1
49	14179	NBR	O-Ring, Drain Plug - 70D	All Models	1
53	45168	AL	Crankcase	All Models except 35GS1	1
	48285	AL	Crankcase (2-set Screw)	45F35GS1	1
64	45179	CM	Pin, Crosshead	All Models	3
65	46644	SHS	Rod, Sleeved, Plunger	All Models	3
69	126585	STCP R	Washer, Seal	All Models	3
70	27339	NBR	Seal, Oil	All Models	3
75	43568	S	Slinger, Barrier	All Models	3
77	25392	NBR	O-Ring, Sleeve - 70D	All Models	3
80	46646	SS	Sleeve	All Models	3
81	29003	PTFE	Back-up-Ring, Sleeve	All Models	3
90	45848	CC	Plunger (M20x24)	All Models	3
100	45183	PVDF	Retainer, Seal	All Models	3
106	45188	NBR	Seal, LPS w/S-Spg	All Models	3
110	45187	BB	Manifold, Inlet	All Models	1
126	45190	BB	Adapter, Female	All Models	3
127	45191	SNG	V-Packing	All Models	6
134	45845	S	Valve, Inlet	All Models	3
135	549520	S	Spacer, Inlet	All Models	3
136	45186	S	Spring, Inlet Valve	All Models	3
137	88575	S	Washer, Conical (M6)	All Models	3
138	27000	S	Nut, Slotted (M6)	All Models	3
139	14158	S	Cotterpin (M1.6x10)	All Models	3
152	43781	NBR	O-Ring, Adapter - 75D	All Models	6
153	21986	PTFE	Back-up-Ring, Adapter	All Models	6
157	45192	BB	Adapter	All Models	3
164	45194	S	Seat	All Models	3
166	43721	S	Valve	All Models	3
167	43751	S	Spring	All Models	3
168	44564	PVDF	Retainer, Spring	All Models	3
185	45193	BB	Manifold, Discharge	All Models	1
188	127027	STCP R	Screw, HSH (M8x100)	All Models	8
197	941517	BB	<i>Assembly, Garden Hose 1/2" (Not Shown)</i>	All Models	1
249	30972	—	Assy, Adapter Mount,	Gas Models Only	1
255	30518	STZP	Assy, Bolt Mount, Gas	40GS1, 45GS1, 50GS1	1
	30511	STZP	Assy, Bolt Mount, 2-set Screw	35GS1	1
	30513	STZP	Assy, Bolt Mount, Electric	40ELS, 45ELS, 50ELS	1
	30974	—	<i>*Assy, Bolt Mount (Short Shaft)</i>	35GS1, 40GS1, 45GS1, 50GS1	1
285	80228	STL	<i>Screw (M8-1.25x80), Engine Removal</i>	All Models	2
300	34054	NBR	<i>Kit, Seal (Incls: 106,127,139,152)</i>	All Models	1
305	34063	NBR	<i>Kit, Sleeve & Seal (Incls: 75,77,80,81,106,127,139,152)</i>	All Models	1
310	34055	NBR	<i>Kit, Discharge Valve (Incls: 152,153,164,166,167,168)</i>	All Models	1
311	34770	NBR	<i>Kit, Inlet Valve (Incls: 134-137, 139, 152)</i>	All Models	1
400	76005	BB	<i>Unloader, Regulating</i>	All Models	1
—	6107	—	<i>Oil, Bottle (21 oz.) ISO-68 Hydraulic (Fill to specified crankcase capacity prior to start-up)</i>	All Models	1

Bold part numbers are unique to a particular pump model. Italics are optional items. R Components comply with RoHS Directive.

See Tech Bulletins 002, 036, 043, 055, 057, 064, 065, 070, 074, 075 and 083 for additional information.

MATERIAL CODES (Not Part of Part Number): AL=Aluminum BB=Brass CC=Ceramic CM=Chrome-moly FCM=Forged Chrome-moly HS=High Strength
NBR=Medium Nitrile (Buna-N) NY=Nylon PTFE=Pure Polytetrafluoroethylene PVDF=Polyvinylidene Fluoride RTP=Reinforced Composite S=304SS SHS=304SS/High Strength
SNG=Special Blend (Buna) SS=316SS STL=Steel STCP=Steel/Chrome Plated STZP=Steel/Zinc Plated

*Substitute special BS Bolt Kit when Briggs-Stratton engine is used. Installation of a shaft retaining bolt, flat washer and lockwasher is also recommended when using the Briggs-Stratton engine to secure key.

EXPLODED VIEW

Electric Models
4SF40ELS, 4SF45ELS,
4SF50ELS
Gas Models
4SF35GS1, 4SF40GS1,
4SF45GS1, 4SF50GS1

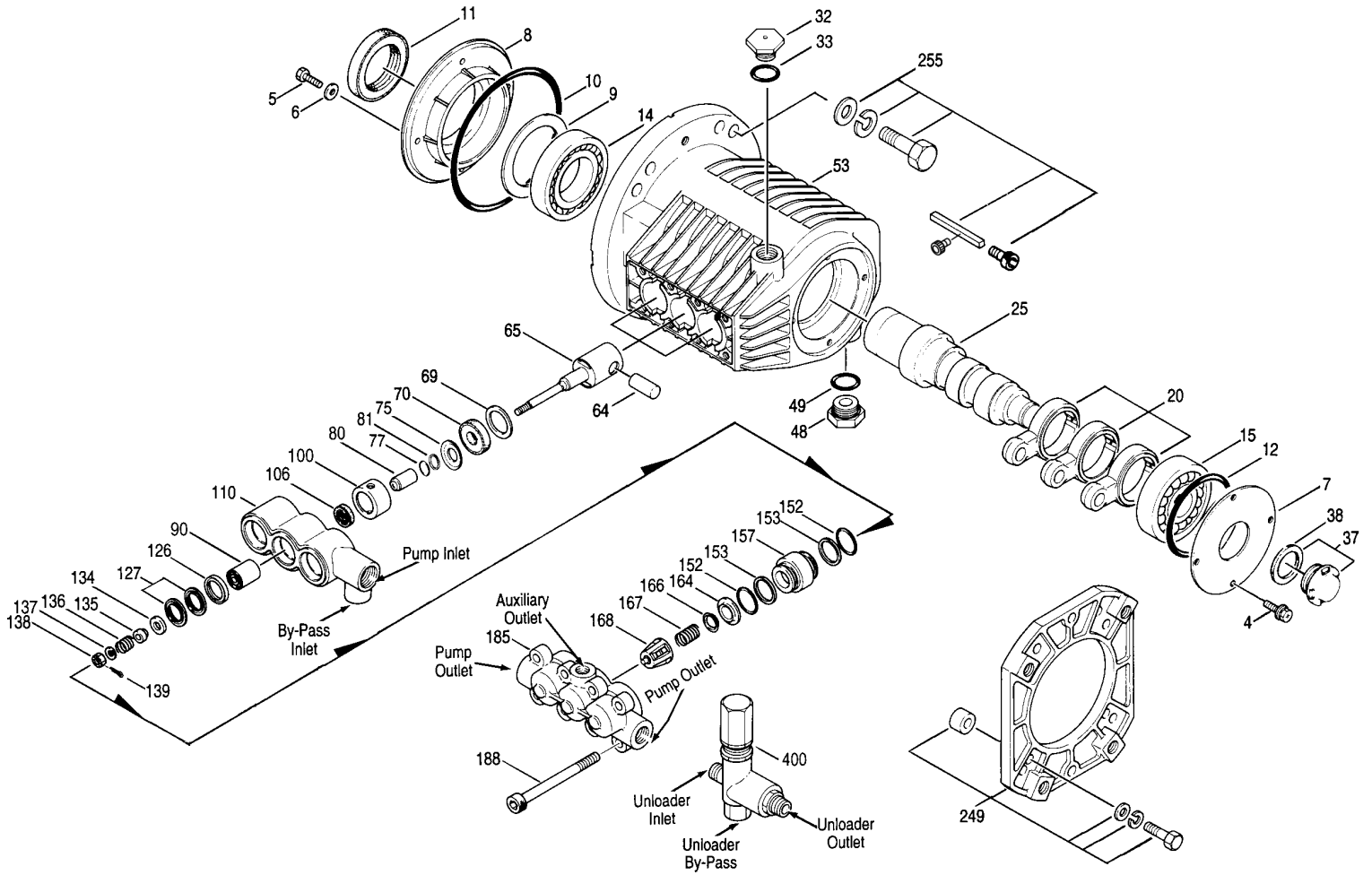

UNLOADER SPECIFICATIONS

MODEL 7600S	U.S.	METRIC
Flow	2.0 - 5.0 gpm	7.6 - 19 lpm
Pressure Range	700 - 3500 psi	50 - 241 bar
Inlet Port - Rear	3/8" NPT(M)	3/8" NPT(M)
Discharge Port - Front	3/8" NPT(M)	3/8" NPT(M)
By-Pass Port - Bottom	3/8" NPT(F)	3/8" NPT(F)
Weight	21.6 oz.	0.61 kg
Dimensions	3.25 x 1.0 x 5.0"	82 x 25 x 127 mm

PARTS LIST

ITEM	PN	MATL	DESCRIPTION	QTY
402	45197	BB	Cap, Hex Adjusting	1
403	45201	BB	Nut, Lock (M25x1)	1
408	45198	ZP	Spring, Pressure	1
410	45199	STZP	Retainer, Spring	1
412	45694	S	Stem, Piston (M5)	1
414	—	PTFE	Back-up-Ring, Piston Stem	1
415	—	NBR	O-Ring, Piston Stem - 70D	1
425	45200	BB	Retainer, Piston	1
428	—	NBR	O-Ring, Piston Guide - 80D	1
429	—	NBR	O-Ring, Body	1
430	—	PTFE	Back-up-Ring, Body	1
435	45716	S	Valve and Ball Assembly (M5)	1
436	107680	S	Seat	1
437	—	NBR	O-Ring, Seat	1
438	45206	S	Seat, Check Valve	1
439	45205	BB	Collar	1
440	—	BB	Body	1
441	—	NBR	O-Ring, Check Valve Seat - 70D	1
442	—	NBR	O-Ring, Adapter - 80D	1
443	35203	BB	Valve, Check w/O-Ring	1
444	45924	S	Spring, Check Valve	1
446	—	NBR	O-Ring, Discharge Fitting - 80D	1
455	45695	BB	Fitting, By-Pass [3/8" NPT(F)]	1
460	107681	BB	Fitting, Discharge [3/8" NPT(M)]	1
468	32098	NBR	Kit, O-Ring (Incls: 414, 415, 428, 429, 430, 437, 441, 442, 446)	1
471	76464	NBR	Kit, Check Valve (Incls: 438, 439, 441, 443, 444, 446)	1

Italics are optional items.

MATERIAL CODES (Not Part of Part Number): BB=Brass NBR=Medium Nitrile (Buna-N) PTFE=Pure Polytetrafluoroethylene S=304SS STZP=Steel/Zinc Plated ZP=Zinc Plated
Refer to 7600S Data Sheet for repair procedure and additional technical information.

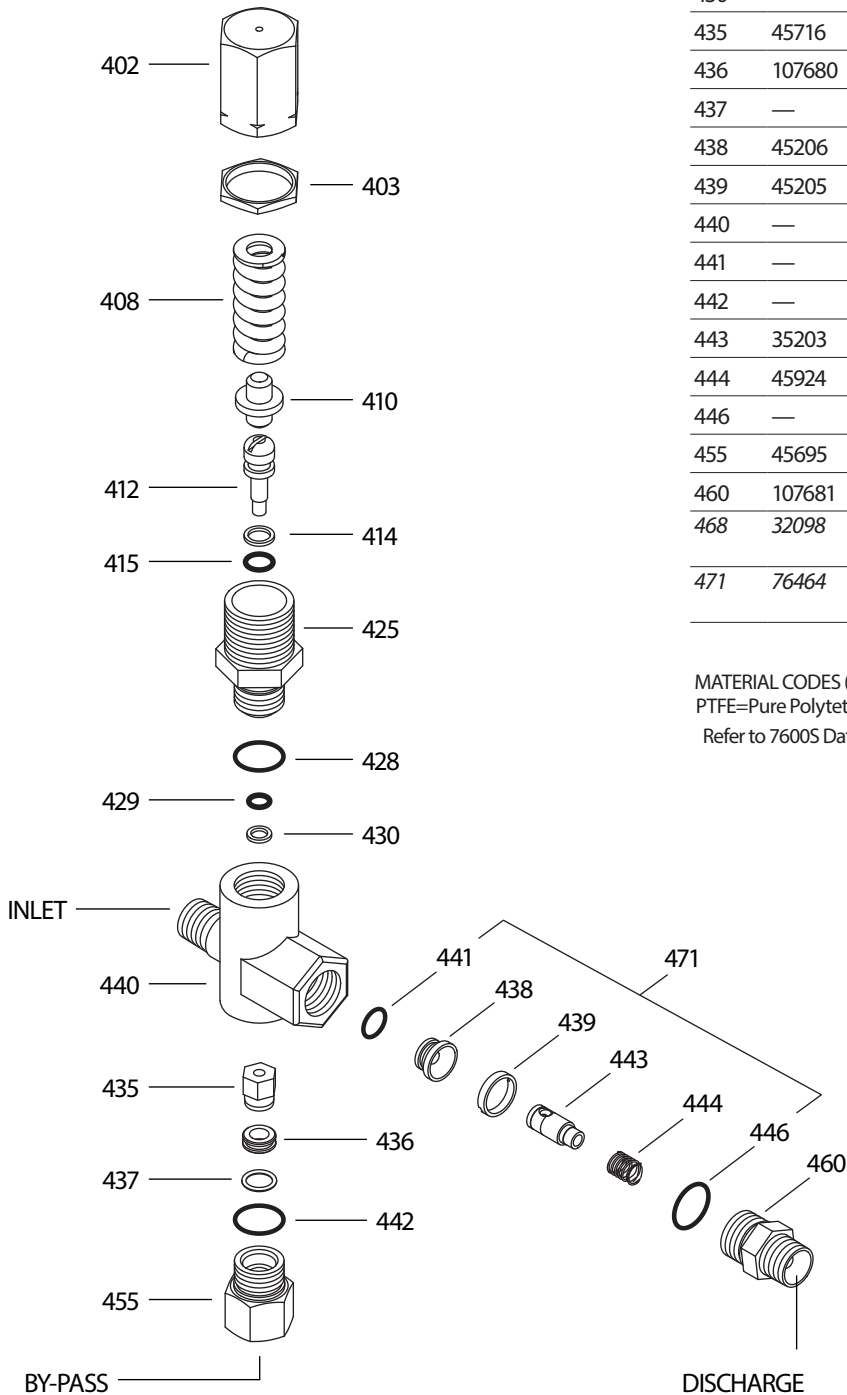

UNLOADER TYPE

Each pump comes with a pressure sensitive regulating unloader. This unloader will set system pressure. While in by-pass the line pressure will drop to a low pressure mode and then quickly build up to set system pressure when the system is back to full use.

INSTALLATION AND START-UP

Install a pressure gauge close to the manifold head of the pump to assist in setting system pressure and to periodically monitor system pressure. By-pass line can be directed to the ground, or to a reservoir or be redirected to the 3/8" NPT(F) port on bottom side of inlet manifold. If routing to pump inlet use a 3/8" flexible hose and thermo valve.

NOTE: If not using a thermo valve **DO NOT EXCEED 6 MINUTES** in by-pass.

Pump should be purged of air before commencing with operation. Liquid must flow through the pump without discharge restriction to assure full system pressure is reached.

Setting and adjusting the unloader pressure must be done with the system turned on. Start the system with the unloader backed off to the lowest pressure setting (counterclockwise direction). Squeeze the trigger and read the pressure on the gauge at the pump. Do not read pressure at the gun or nozzle. If more pressure is desired, release the trigger, turn adjusting cap one quarter turn in a clockwise direction. Squeeze the trigger and read the pressure. Repeat this process until the desired system pressure is reached. Thread locking nut up to adjusting cap.

NOTE: Pressure is not set at the factory.

SERVICE

The unloader should be serviced on the same schedule as the seals in the pump. Refer to SF Plunger Pump Service Manual for start-up, servicing of seals and valves, torque requirements and diagnosis and maintenance chart.

NOTE: For maximum suction capability, regulating unloader should be remounted on discharge manifold, opposite from inlet port.

CHEMICAL INJECTOR PERFORMANCE CHART

Desired Pump Flow	Injector Orifice Size	Injector Model	Lo-Pressure Nozzle (Maximum injecting pressure less hose friction loss)	Max. Chem. Draw (0 PSI) (Downstream)	Hi-Press Nozzle "Deduction" (Press. drop across Inj.)
3.5	2.1 mm	7193	300 PSI	50 oz/min	200 PSI
3.5	2.3 mm	7194	185 PSI	56 oz/min	175 PSI
4.0	2.1 mm	7193	375 PSI	54 oz/min	250 PSI
4.0	2.3 mm	7194	225 PSI	50 oz/min	225 PSI
4.5	2.1 mm	7193	485 PSI	54 oz/min	325 PSI
4.5	2.3 mm	7194	260 PSI	50 oz/min	285 PSI
5.0	2.3 mm	7194	300 PSI	50 oz/min	350 PSI

Optimum performance of chemical injector occurs with a 35 ft. high pressure hose and a minimum 3/8" I.D. The type of hose, extended lengths, reduced I.D. and fittings may create back pressures in excess of the low pressure nozzle rating and prevent the injector from drawing chemical. Deduct hose friction loss from above low PSI Nozzle.

CHEMICAL INJECTOR SPECIFICATIONS

MODEL	7194	7193
Flow	4 - 5 gpm	3 - 4 gpm
Nozzle Orifice	2.3 mm	2.1mm
Hose Barb	1/4"	1/4"
Inlet Port	M18 x 1.0	M18 x 1.0
Discharge Port	3/8" NPT(M)	3/8" NPT(M)
Weight	6.3 oz.	6.3 oz.
Dimensions	2 x 1 x 3"	2 x 1 x 3"

PARTS LIST

ITEM	PN	MATL	DESCRIPTION	MODEL USED	QTY
446	26133	NBR	O-Ring, Body - 80D	All Models	1
471	33949	NY	Handle, Adjustment	All Models	1
472	—	BB	Barb, Adjustable	All Models	1
473	—	NBR	O-Ring, Hose Barb	All Models	1
474	—	S	Spring	All Models	1
475	—	BB	Retainer, Ball Seat	All Models	1
476	—	FPM	O-Ring, Retainer	All Models	1
477	—	SS	Ball	All Models	1
478	—	SS	Spring, Tapered	All Models	1
479	32374	S	Orifice, Injector (2.3 mm) Standard	7194	1
	32373	S	Orifice, Injector (2.1mm)	7193	1
480	—	BB	Body	All Models	1
481	33481	BBNY	Barb Assembly, Adjustable (Incls: 471, 472, 473, 474, 475, 476, 477, 478)	All Models	1

Italics are optional items.

MATERIAL CODES (Not Part of Part Number): BB=Brass FPM=Fluorocarbon
NBR=Medium Nitrile (Buna-N) NY=Nylon S=304SS SS=316SS

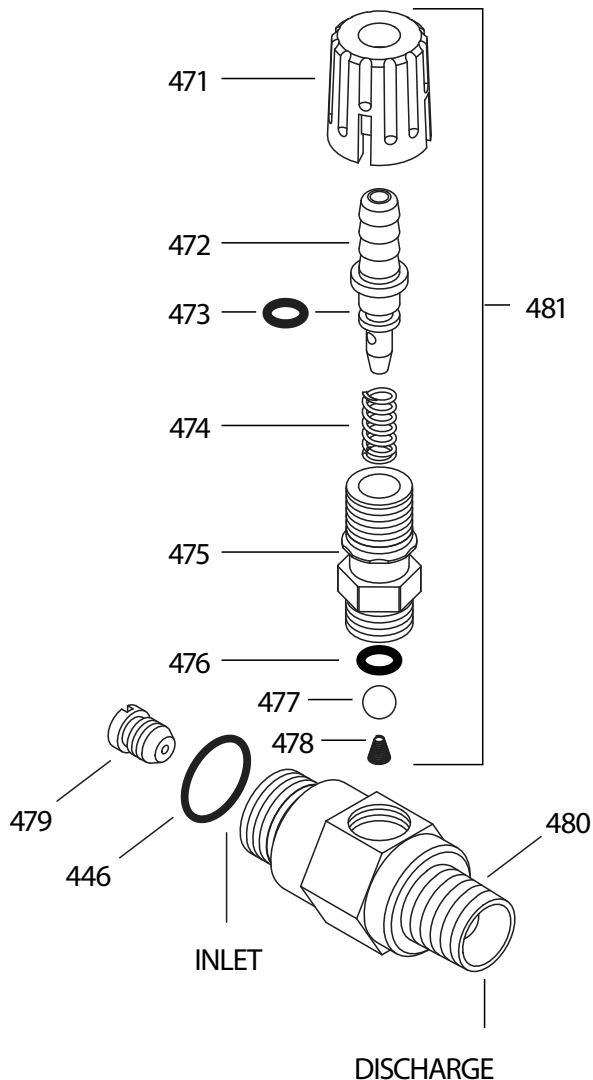

ELECTRIC MOTOR SPECIFICATIONS

Model 999839

Horsepower	3.0
Shaft Diameter	1-1/8"
Maximum Volts	208-230/460
Full Load Amps	14.7-13.6/6.8
RPM	1750
Weight	99 lbs.
Phase	Single
Frame Size	184TC
Service Factor	1.15

Model 999809

Horsepower	3.0
Shaft Diameter	1-1/8"
Maximum Volts	208-230/460
Full Load Amps	8.4-7.6/3.8
RPM	1750
Weight	100 lbs.
Phase	Three
Frame Size	182/184TC TEFC
Service Factor	1.15**

** Service Factor at 208V = 1.00

Model 997634

Horsepower	5.0
Shaft Diameter	1-1/8"
Maximum Volts	208-230/460
Full Load Amps	22.5-21.4/10.7
RPM	1750
Weight	113 lbs.
Phase	Single
Frame Size	184TC
Service Factor	1.15**

** Service Factor at 208V = 1.00

Model 996543

Horsepower	5.0
Shaft Diameter	1-1/8"
Maximum Volts	208-230/460
Full Load Amps	14.3-12.9/6.45
RPM	1750
Weight	104 lbs.
Phase	Three
Frame Size	182/184TC TEFC
Service Factor	1.25**

** Service Factor at 208V = 1.15

Model 998517

Horsepower	7.5
Shaft Diameter	1-1/8"
Maximum Volts	208-230/460
Full Load Amps	32.0-30.6/15.3
RPM	1750
Weight	180 lbs.
Phase	Single
Frame Size	213/215TCZ*
Service Factor	1.15**

* Frame size - 213/215TC w/ 184C Face ** Service Factor at 208V = 1.00

Model 999800

Horsepower	7.5
Shaft Diameter	1-1/8"
Maximum Volts	208-230/460
Full Load Amps	19.9-18.4/9.18
RPM	1750
Weight	168 lbs.
Phase	Three
Frame Size	213/215TCZ*
Service Factor	1.25**

* Frame size - 213/215TC w/ 184C Face ** Service Factor at 208V = 1.15

Model 8046

Horsepower	10.0 H.P.
Shaft Diameter	1-1/8"
Maximum Volts	208-230/460 V
Full Load Amps	28/26/13 AMPS.
RPM	1725
Weight	140.1 lbs.
Phase	Three
Frame Size	215 TCZ TEFC*
Service Factor	1.15

* Frame size - 213/215TCZ w/ 184C Face

Common Motor Specifications

Max. Ambient Temperature	104° F
Hertz	60 Hz
Capacitor Start	Yes

Note: Motor Start-Up AMPS may vary, then settle within FULL LOAD AMPS rating after initial run in time.

Before mounting pump on motor, apply P.N. 6106 Antiseize Lubricant to pump shaft.

Refer to Tech Bulletin 055 for instructions on removing pump from electric motor.

DETERMINING THE REQUIRED H.P.

$$\text{Hp (Electric Brake)} = \frac{\text{gpm} \times \text{psi}}{1460}$$

For electric motor warranty consideration contact motor manufacturer's local Authorized Service Center.

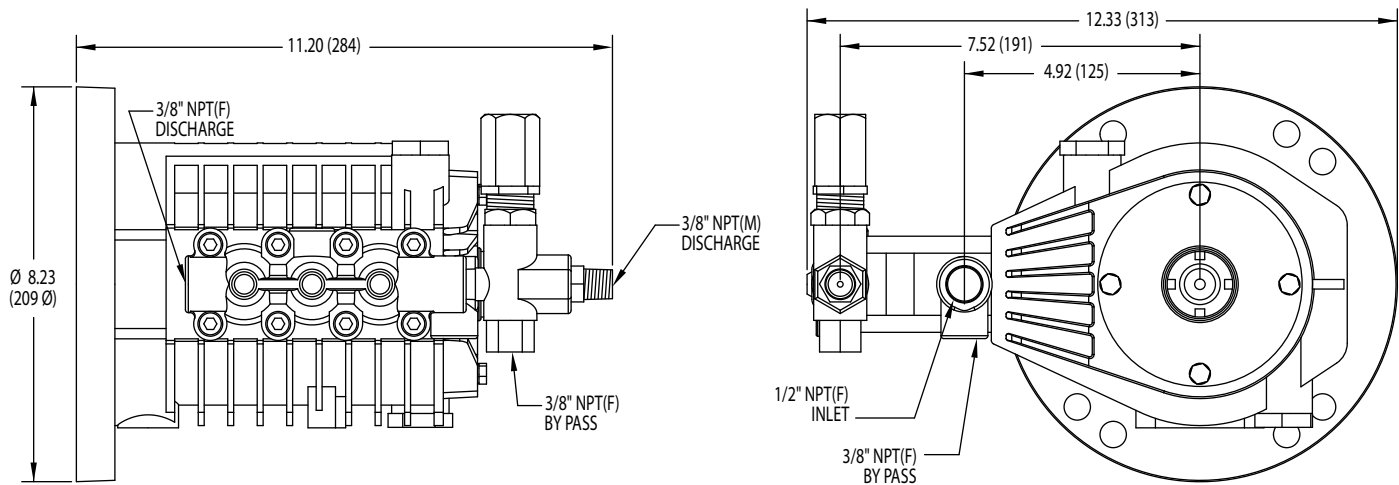

⚠ CAUTIONS AND WARNINGS

All High Pressure Systems require a primary pressure regulating device (i.e. regulator, unloader) and a secondary pressure relief device (i.e. pop-off valve, relief valve). Failure to install such relief devices could result in personal injury or damage to pump or property. Cat Pumps does not assume any liability or responsibility for the operation of a customer's high pressure system.

Read all CAUTIONS and WARNINGS before commencing service or operation of any high pressure system. The CAUTIONS and WARNINGS are included in each service manual and with each Accessory Data sheet. CAUTIONS and WARNINGS can also be viewed online at www.catpumps.com/cautions-warnings or can be requested directly from Cat Pumps.

WARRANTY

View the Limited Warranty on-line at www.catpumps.com/warranty.

	<p>CAT PUMPS 1681 - 94TH LANE N.E. MINNEAPOLIS, MN 55449-4324 PHONE (763) 780-5440 — FAX (763) 780-2958 e-mail: techsupport@catpumps.com www.catpumps.com</p>
---	--